

ETI

Hardware controller for switching, mixing, converting, and generating trigger signals

User manual

Document version: 1.4

Date of issue: 2026-05-26

Document language: EN

Translation of German original

Use Anybody working with/on the device has to have read and understood the relevant parts of this document.

Access The staff working with the device has to have constant access to this document to prevent handling errors and guarantee trouble-free operation.

Reproduction All information in this document is protected by copyright. This document must not be copied, distributed or changed in any way by anyone including business units or departments of point electronic GmbH without prior written approval by point electronic GmbH. Reproduction and use of this document are confined to internal purposes of the operator only.

Up-to-datedness Every endeavor has been made to make sure that the information contained in this document is complete and correct at the printing date. This document describes all units and functions known of at the current point of time.

Brand names, company names and product names The brand names, company names and product names used in this document are the brand names, company names, or product names of the respective manufacturers and/or owners.

Contact us point electronic GmbH
Erich-Neuß-Weg 15
06120 Halle (Saale)
Germany
Phone: +49 345 1201190
Email: info@pointelectronic.de
Web: <https://www.pointelectronic.de>

Product information Product: ETI
Description: Hardware controller for switching, mixing, converting, and generating trigger signals
Name: PE-ETI
Manufacturer: point electronic GmbH

Table of contents

1	Introduction	5
	Validity of this document	6
	User groups of this document	7
	Structure of this document	8
	Representations in this document	9
	Identification of the warning notices	10
	Topics relevant to service	11
2	Safety regulations	12
	Introduction	13
	Basic hazards	14
	Staff and qualifications	15
	Responsibility of the operating company	16
	Working in a safety-conscious manner	17
	Modifications and alterations	18
	Maintenance work	19
	Cleaning	21
	Environmental protection	22
3	System overview	23
	Intended use	24
	Improper use	25
	Device description	26
	Scope of delivery	30
	System environment requirements	31
	Front panel	32
	Back panel	33
	Touch display	35
	Device labeling	38
	Camera trigger cable	40
4	Pinouts of the inputs and outputs	41
	LVDS – OUTPUT	42
	TTL – OUTPUT	43
	LVDS – INPUT 1/2	44
	TTL – INPUT 1/2	45
	AUX – INPUT 1	46
5	Installation and configuration	47
	Mounting in a 19-inch rack	48
	Connecting to the power supply	50
6	Maintenance	51
	Disconnecting from the power supply	52
	Replacing the fuses	53
7	Disposal	55
	Recycling and taking back of used equipment	56

8	Specifications	57
	Operating conditions	58
	Device specifications	59



1 Introduction

Chapter overview

Purpose This chapter contains information to simplify working with this document.

Contents This chapter contains the following information:

- › Validity of this document 6
- › User groups of this document. 7
- › Structure of this document 8
- › Representations in this document. 9
- › Identification of the warning notices. 10
- › Topics relevant to service 11

Validity of this document

Validity for device This document applies to the following device:

Device	Part number
ETI (19-inch rack-mount device, 2U)	1019 0001 0001

Validity for factory-default state This document applies to the device listed above in the condition in which it was placed on the market.

If the end user subsequently adds parts or makes modifications to the device listed above, this will result in the complete invalidation of this document.

User groups of this document

Operators "Operators" are persons with right of disposal over the device using this right for purchase or other purposes.

Technical staff "Technical staff" are those persons that the operators entrust with tasks related to use and operation. Technical staff are trained by the operators to carry out their assigned tasks and are informed on the potential hazards that may arise due to improper handling.

Technical staff need to undergo a training by point electronic GmbH or a partner company of point electronic GmbH covering the following topics:

- Areas of application and operation of the device and the associated software
- Handling the connected peripherals
- Basic maintenance tasks and troubleshooting

Service technicians "Service technicians" are staff members whose specialist training, knowledge and experience as well as familiarity with the relevant safety regulations mean they are able to assess the tasks they have been entrusted with and anticipate potential hazards.

Service technicians may be:

- Employees of point electronic GmbH or
- Employees of partner companies of point electronic GmbH







Structure of this document

- Outline** This document is structured into chapters which are organized by technical aspects.
- Numbering** The chapters are numbered by Arabic numerals. Chapters may be structured in sections. Sections are numbered as second numbering level (e. g. 3.1). Sections are used to structure large chapters into sub-chapters.
- All pages of this document are numbered consecutively.
- Overviews** Each chapter and section contains an overview detailing contents and page numbers. This allows for direct access to a topic and independent use of single parts of this document.
- Related information** Related information within the user guide is marked by the note "Continuation next page ..." resp. "... Continuation". Please pay attention to the completeness of thus marked information when copying parts of the document.
- Cross references** The content of this document is structured by topics. If further information on one topic may be found elsewhere in the document, the relevant chapter and page are pointed out.

Representations in this document

Illustrations Illustrations used in this document do not always contain all details or special cases. They only represent the relevant information.

Icons The following icons are used to mark certain information visually:

Icon	Meaning
	Notice For example:  The selected parameter will not be inserted in the parameter order.
	Reference to another part of this guidebook For example:  see "Cross references" on page 8
	Use of a tool For example:  Screwdriver TX 10

Notes Important notes are marked as follows:

NOTICE

Mind the notices in this document!





Notes explain relations that even for expert users might not be evident at first glance.

The neglect of a note is no direct security risk. However, it can lead to disturbances in the operating procedure.

Identification of the warning notices

Purpose This document includes warning notices that may lead to serious consequences if disregarded. Warning notices are not only listed in the “Safety regulations” chapter, but especially in places where hazards for people, equipment and operation may arise.

Identification of hazards There are four classes of hazards. These classes are indicated by specific signal words and colors. They include the following:

Signal word	Meaning
 DANGER	Warning notice, which if disregarded will surely or very likely result in death or serious injury.
 WARNING	Warning notice, which if disregarded will probably result in serious injury, permanent damage to health or serious property loss.
 CAUTION	Warning notice, which if disregarded will probably result in injury or property loss including financial losses due to operational impairment.
 ATTENTION	Warning notice, which if disregarded will probably result in property loss including financial losses due to operational impairment.

Topics relevant to service

Service contact For detailed information and questions about topics such as installation and configuration, please contact our service department at:

service@pointelectronic.de

Further documents Additional documents with descriptions and instructions for installation, configuration, and additional software tools are available in protected public areas.

If you require access to further documents, please contact our service department at:

service@pointelectronic.de



2 Safety regulations

Chapter overview

Purpose This chapter contains safety information relating to the protection of persons as well as safe and fault-free operation. All user groups of the hardware and software must be aware of and follow these safety provisions.

Contents This chapter contains the following information:

› Introduction	13
› Basic hazards	14
› Staff and qualifications	15
› Responsibility of the operating company	16
› Working in a safety-conscious manner	17
› Modifications and alterations	18
› Maintenance work	19
› Cleaning	21
› Environmental protection	22

Introduction

Reliable and safe operation The reliable and safe operation of the device depends on carefully implementing the operating, setup and maintenance tasks.

Observance of the safety instructions Always observe and follow the safety instructions and accompanying code of conduct when handling the device and the software. Always point out the instructions and code of conduct to staff working with the hardware and software.

Generally applicable safety regulations (such as accident prevention and environmental protection regulations, etc.) must also be observed.

Consequences arising from failure to observe the safety instructions Failure to observe the safety instructions can result in death or serious injury of personnel and damage or destruction of the hardware components.

Basic hazards

Definition The device meets the current state of the art as well as the applicable safety regulations. The device has been tested at the manufacturer's site and is delivered in a state safe for operation.

Basic hazards are residual risks that may arise despite proper and safety-conscious use of the device.

DANGER

Risk of death by electrocution!

Body contact with live parts may lead to death or serious injuries.

- Turn off the mains voltage before any works on the device.
- Secure the device against unintentional restart.
- Works on the device may only be executed by service technicians.
- Never operate the device when the mains cable is damaged.

WARNING

Risk of injury due to improper use!

Improper use of the device may lead to injury.

- Always protect the device from extreme heat (excessive sun exposure, close proximity to open fire or heating equipment) during operation and storage.
- Avoid hard impacts that might damage parts of the device.

Staff and qualifications

Permissions Works on/with the device may only be performed by technical staff and/or service technicians (🔑 see "User groups of this document" on page 7).

Note the legally prescribed minimum age for personnel.

Only qualified electricians or technical staff under guidance and supervision of a qualified electrician may perform works on electrical components of the device in accordance with the electrotechnical regulations.

Staff undergoing training or instructions or persons taking part in general vocational training programs may only operate the device under the continuous supervision of technical staff.

Responsibility of the operating company

Condition of the device and/or overall system The operating company shall ensure that all safety and the protective devices are fully functional at all times. This equipment should therefore be checked periodically for functionality and completeness.

This applies to the device as single component as well as the overall system into which the device is integrated as a subcomponent.

Internal measures to avoid hazards The operating company must be aware of the applicable industrial safety regulations and use a risk assessment to determine any additional hazards that may arise from the special working conditions at the device's site of operation. Internal instructions for avoiding the identified hazards should then be drawn up.

Throughout the entire operating period of the device, the operating company must examine and determine whether the supplied operating instructions comply with the current status of applicable regulations.

Staff Regarding the staff authorized or trained by the operating company, the operating company carries the following responsibilities:

- The necessary training and instruction of staff must be guaranteed.
- The powers and responsibilities of staff for installation, operation, maintenance and service must be clearly defined and documented.
- This document must be kept in the immediate surroundings of the device and must be readily accessible to staff.

Working in a safety-conscious manner

Accident prevention and environmental protection In addition to the information in this document, also note the generally applicable statutory and other binding regulations relating to accident prevention and environmental protection.

This may include, for example:

- dealing with hazardous substances
- wearing the necessary and prescribed personal protective clothing
- observance of and compliance with all national and regional industrial safety regulations
- observance of and compliance with all internal working, operating and safety regulations

Content of this document Prior to operation, all staff members assigned to work on the device must have read and understood the relevant parts of this document, especially the chapter “Safety regulations”.

Modifications and alterations

No unauthorized modifications Any unauthorized modifications to the device exclude any liability by the manufacturer for resulting damage and consequences.

Do not perform any modifications, additions and/or alterations to the device without written authorization from point electronic GmbH.

Spare parts and accessories Spare parts and accessories must comply with the technical requirements specified by point electronic GmbH and its suppliers. Whenever original parts are used, compliance is given.

No modifications of the software No modifications to the software must be made or commissioned to third parties. The software may not be deleted, decrypted or decompiled in full or in part.

If changes to the software are necessary, please contact point electronic GmbH.

Maintenance work

Implementation High reliability as well as low maintenance costs of the device may be achieved through careful implementation of the maintenance schedule and regular monitoring over the entire operational lifetime.

Compliance with regulations When performing maintenance work, it is essential to observe the following:

- applicable accident prevention regulations,
- applicable environmental protection regulations and
- safety instructions for maintenance work.

Only perform maintenance work if:

- you are authorized to do so and
- the device is turned off and secured against unintentional restart.

Before getting started Before you begin maintenance work, please make sure that:

- the device is de-energized and disconnected from the power supply and
- the power supply may not be re-established unintentionally as long as the maintenance work lasts.

Works during operation In any case, the operating company or the personnel employed by it must check based on the specific local conditions that the specified work may be performed during operation without endangering anybody.

Continuation next page ...

Electrical equipment Regularly check the electrical equipment of the device. Immediately rectify defects (such as loose cable connections and/or faulty cables).

Damaged or faulty cables may only be replaced by cables that match the requirements stipulated by point electronic GmbH and/or its suppliers!

Check that the surfaces of all electrical equipment parts are dry and free of oil, grease, deposits and corrosion.

Only use voltage-insulated tools!

Do not place any tools or working materials on the conductive surfaces of components.

Device fuses Faulty fuses may only be replaced by fuses that match the requirements (specifications and ratings) stipulated by point electronic GmbH!

Faulty fuses may not be repaired or bypassed, but must be replaced by fuses of the same type.

Cleaning

Requirements Do not open the device! It contains no parts that require cleaning by the operator.

Suitable cleaning products Only use cleaning products approved by point electronic GmbH.

All cleaning products used by the customer should be checked with point electronic GmbH or the respective supplier to ensure they are compatible with the materials and colors used.

Unsuitable cleaning agents Do not clean the device with:

- scratchy, aggressive cleaning agents containing solvents, gasoline, or alcohol,
- pressured air, high-pressure cleaner or other kinds of cleaning machine.

Cleaning equipment Use lint-free cleaning cloths/wipes for cleaning the device. To remove stubborn dirt, use lint-free cleaning cloths/wipes moistened with clear water.

After cleaning After cleaning, make sure that:

- cables, ports and fittings are free of oil and/or cleaning agents and
- cables, wires, connectors and electrical components are dry.

Environmental protection

Recyclable materials When performing maintenance work, ensure that reusable materials are recycled.

Disposal Electrical and electronic waste may constitute a hazard to health and environment when disposed off improperly. According to WEEE Directive 2012/19/EU (Waste Electrical and Electronic Equipment Directive), electrical and electronic waste may not be disposed off as general domestic waste but must be handed in at specific collection points or sent back to the manufacturer.

Check with your local environmental protection agency for the prescribed disposal options for commercially used electronic waste.

Only hire waste disposal companies that are approved by the national and regional authorities.



3 System overview

Chapter overview

Purpose This chapter describes the device. It contains information on the use, scope of delivery, equipment, structure and function.

Contents This chapter contains the following information:

› Intended use	24
› Improper use	25
› Device description	26
› Scope of delivery	30
› System environment requirements	31
› Front panel	32
› Back panel	33
› Device labeling	38
› Camera trigger cable	40

Intended use

Purpose The External Trigger Interface (ETI) is a universal, stand-alone hardware controller for switching, mixing, converting, and generating trigger signals between scan controllers, high-speed cameras, and/or beam blankers.

The ETI is designed for installation and operation in a 19-inch rack.

Operation The device may only be operated in a technically perfect condition and as intended, in compliance with the user manual and under consideration of safety and potential hazards. Malfunctions, in particular those that may impair safety, should be rectified immediately.

If the device shows damages or defects that compromise operational safety, this must immediately be reported to the operations center, and the device must not be put into operation.

Operation and maintenance of the device may only be performed by technical staff and service technicians (🔑 see "User groups of this document" on page 7). The valid safety and accident prevention regulations must be observed.

Compliance with regulations All operating, maintenance, setup and service measures prescribed by the manufacturer must be complied with.

Additional information In addition to this document, the generally applicable, legal and other binding regulations and legislation and environmental protection instructions must be adhered to.

Improper use

Any use not authorized by the manufacturer is not permissible and may lead to injury or property damage.

point electronic GmbH does not accept liability for damage arising from improper use of the device.

In particular, improper use includes:

- operation in explosive environments
- operation in an environment that does not meet the stipulated requirements
 -  see “Operating conditions” on page 47
- operation with opened device housing
- operation with visible damage to the device and/or peripherals (e.g. connected cables, etc.)
- modifications and/or additions that impair the performance
- exchanging components with unauthorized components

Device description

Structure The ETI is housed in a 19-inch enclosure with two rack units (2 U) and equipped with:

- a touch display on the front for controlling and displaying status,
- a switchable power supply,
- two trigger inputs and
- one trigger output.

Trigger signals The inputs and outputs include trigger signals in TTL and LVDS for pixels, lines, image, and beam blanker. The following definitions are used to describe the trigger signals:

Definition	Description
Signal type	TTL, LVDS
Signal mode	Pixel, Line, Frame, Beam Blanker

The trigger signals can be switched, mixed, or converted.

Switching and mixing are applied to both TTL and LVDS inputs, allowing TTL and LVDS signals to be used.

Manual switching of trigger signals With the ETI, trigger signals from two input channels can be manually switched to the output channel.

A typical example is a camera with one frame trigger input and two scan controllers, each with one pixel trigger output. The scan controllers output TTL or LVDS triggers for each new pixel in their scans. The camera is set to acquire new frames for each trigger input.

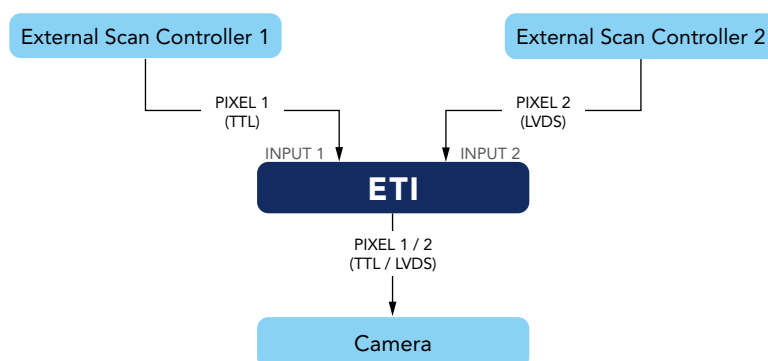

The scan controllers can be operated sequentially or simultaneously.

Continuation next page ...

The touch display of the ETI can be used to set manual switching of the trigger signals as follows:

- manually switch to Input 1
- manually switch to Input 2

It is possible to switch between the TTL and LVDS signal types.

Automatic switching of trigger signals

Optionally, the scan controllers can have an additional external scan connection to the ETI, allowing a scan controller to automatically switch the connection to its output.

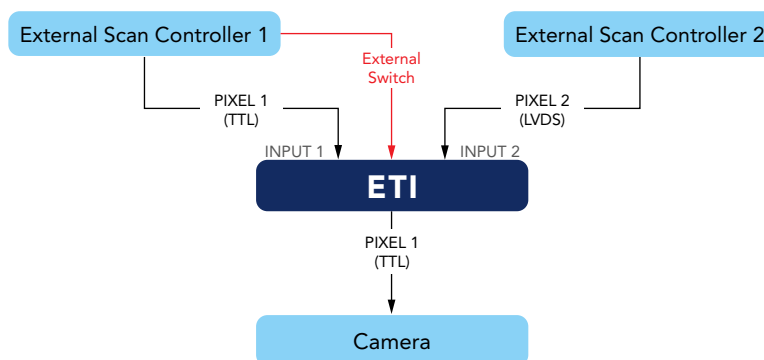

The diagram shows an example configuration in which the ETI is set to external switching on input 2 (touch display: Switch 1 -> 2). In this example:

- When the external switch signal is “low” the trigger signal from external scan controller 1 is transmitted to the camera. The trigger signal from external scan controller 2 is ignored.
- When the external switch signal is “high” the trigger signal from external scan controller 1 is ignored. The trigger signal from external scan controller 2 is transmitted to the camera.

The touch display of the ETI can be used to set automatic switching of the trigger signals as follows:

- external switching for input channel 2 (Switch 1 -> 2)
- external switching for input channel 1 (Switch 2 -> 1)

It is possible to switch between the TTL and LVDS signal types.

Continuation next page ...

Mixing trigger signals With the ETI, trigger signals from two input channels can be mixed into one output signal.

A typical example is a beam blanker that must open when one of two scan controllers detects signals for pixels.

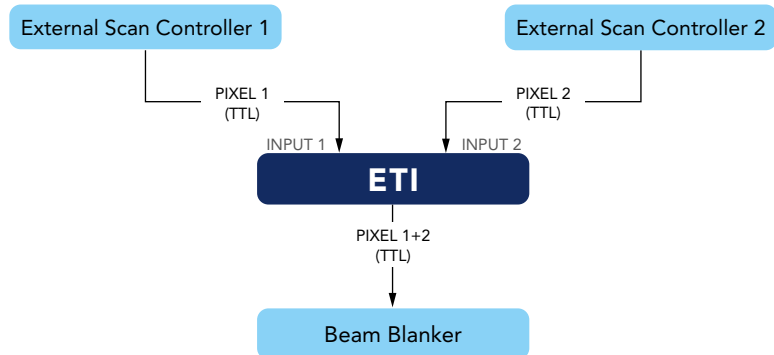

Mixing different signal types (TTL/LVDS) is possible.

NOTICE

Note the signal mode of the input trigger signals!

Input trigger signals of the same signal mode can be mixed (e.g. pixels from input channels 1 and 2).

It is not possible to mix input trigger signals of different signal modes (e.g. pixels from input channel 1 and line from input channel 2).

Converting trigger signals With the ETI, trigger signals can be converted from TTL to LVDS and from LVDS to TTL.

A typical example is synchronization between a scan controller with LVDS output for pixel triggers and a camera with TTL input – or vice versa.

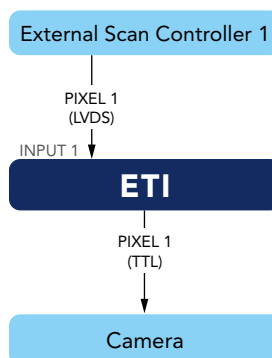

Continuation next page ...

Generating trigger signals With the ETI, custom trigger signals can be generated.

The generator function is used for testing purposes to check whether the trigger is correctly fed into a device.

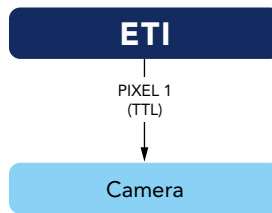

When using the generator function, the trigger signals of the two input channels are ignored.

The touch display of the ETI can be used to activate the following signal generator:

- 1 kHz Generator

Scope of delivery

The following basic equipment is part of the scope of delivery:

Component	Part number
ETI External Trigger Interface (device)	1019 0001 0001
Mains power extension cable (C13 to C14, 2 m)	1000 0001 0001
LAN cable (RJ-45, CAT.6, 3 m)	1000 0006 0005
D-SUB 15 cable (2 m)	1000 0008 0001
Camera trigger cable (D-Sub 15 to LEMO 00, 3 m)	1019 0002 0001
 page 40	
USB stick with documentation	

NOTICE

The complete scope of delivery depends on the respective order.

System environment requirements

Minimum requirements The following table contains information on the minimum system requirements:

Component	Requirement
Power connection	At least one socket: <ul style="list-style-type: none">– 115 ... 230 V AC– 50 ... 60 Hz– Single-phase– Same grounding as the microscope
Mounting	Space of 2 U in a 19 inch rack

Front panel

Structure The following figure shows the front panel of the device with its components:

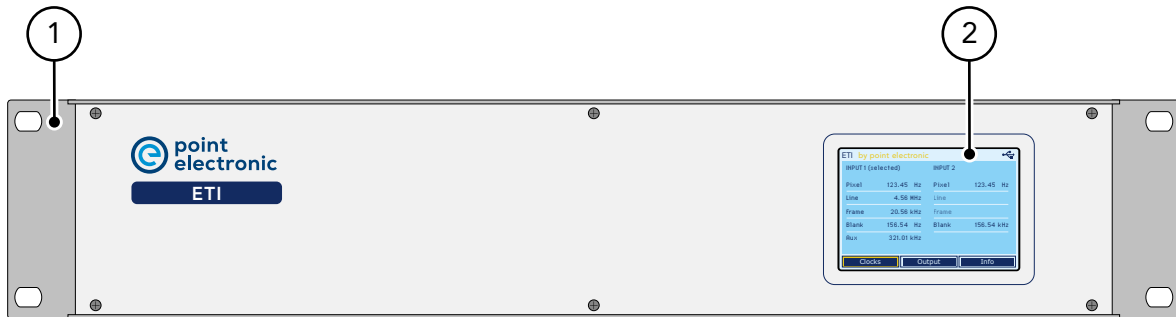

Components The following table contains information on the components of the front panel:

No.	Component
1	19" mounting brackets for installation in a rack
2	Touch display <ul style="list-style-type: none"> – Displays status and system information for the device – Enables configuration of the device
	 see "Touch display" on page 35

Back panel

Structure The following figure shows the back panel of the device with its components:

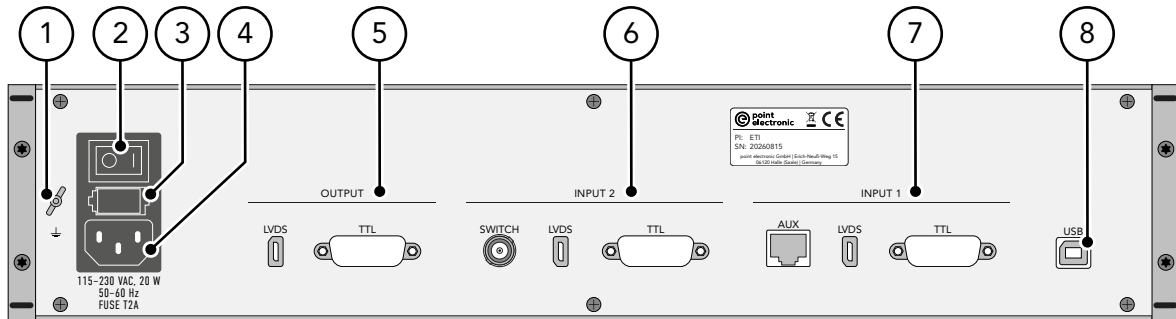



Components The following table contains information on the components of the back panel:



No.	Component
1	Grounding connector
2	On/off switch i The on/off switch is not a load-breaking switch!
3	Fuses – 2 pieces (L and N) – Replaceable – Type: T2A
4	Mains voltage connector – 115 ... 230 V AC, 20 W, 50 ... 60 Hz – Type: C14 male
5	Connectors for output trigger signals i see "OUTPUT connectors" on page 34
6	Connectors for input trigger signals (input channel 2) i see "INPUT 2 connectors" on page 34
7	Connectors for input trigger signals (input channel 1) i see "INPUT 1 connectors" on page 34
8	USB – Connection for service (e.g. firmware updates) – Type: USB type B, socket (female)

Continuation next page ...



OUTPUT connectors The following table contains information on the connectors for the output signals:

Connector	Description
LVDS	Connector for differential output trigger signals – Type: 10 Pin, ix Industrial, perpendicular upright, socket (female), type B – Corresponds to IEC 61076-3-124  Pinout: page 42
TTL	Connector for single-ended output trigger signals – Type: 15 Pin, D-Sub, socket (female)  Pinout: page 43

INPUT 2 connectors The following table contains information on the connectors of input channel 2:

Connector	Description
SWITCH	Connector for switchover signal – Type: BNC, socket (female)
LVDS	Connector for differential input trigger signals – Type: 10 Pin, ix Industrial, perpendicular upright, socket (female), type A – Corresponds to IEC 61076-3-124  Pinout: page 44
TTL	Connector for single-ended input trigger signals – Type: 15 Pin, D-Sub, plug (male)  Pinout: page 45

INPUT 1 connectors The following table contains information on the connectors of input channel 1:

Connector	Description
AUX	Connector for external differential input trigger signals – Type: RJ-45, socket (female)  Pinout: page 46
LVDS	Connector for differential input trigger signals – Type: 10 Pin, ix Industrial, perpendicular upright, socket (female), type A – Corresponds to IEC 61076-3-124  Pinout: page 44
TTL	Connector for single-ended input trigger signals – Type: 15 Pin, D-Sub, plug (male)  Pinout: page 45

Touch display

Description The touch display shows status and device information on three switchable pages and allows the output trigger signals to be configured.

Clocks The Clocks page displays information about the current status and the configured input signal.

The following figure shows the touch display with the Clocks page:

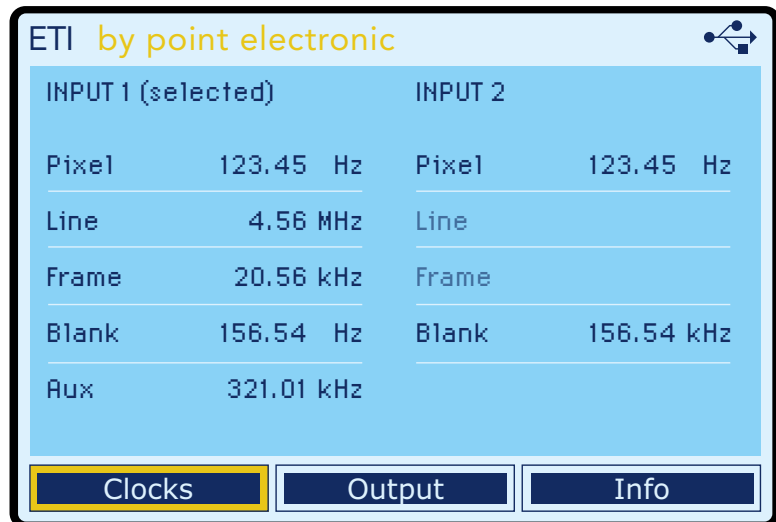

INPUT 1 (selected)		INPUT 2	
Pixel	123.45 Hz	Pixel	123.45 Hz
Line	4.56 MHz	Line	
Frame	20.56 kHz	Frame	
Blank	156.54 Hz	Blank	156.54 kHz
Aux	321.01 kHz		

Navigation buttons: Clocks (highlighted), Output, Info

The Clocks page is divided into columns for each input channel. These columns display the following information:

- The input channel selected depending on the configuration.
- The current values of the input signals. Input signals that are not available are displayed in gray.

Continuation next page ...

Output On the Output page, the output trigger signals can be configured.

The following figure shows the touch display with the Output page:

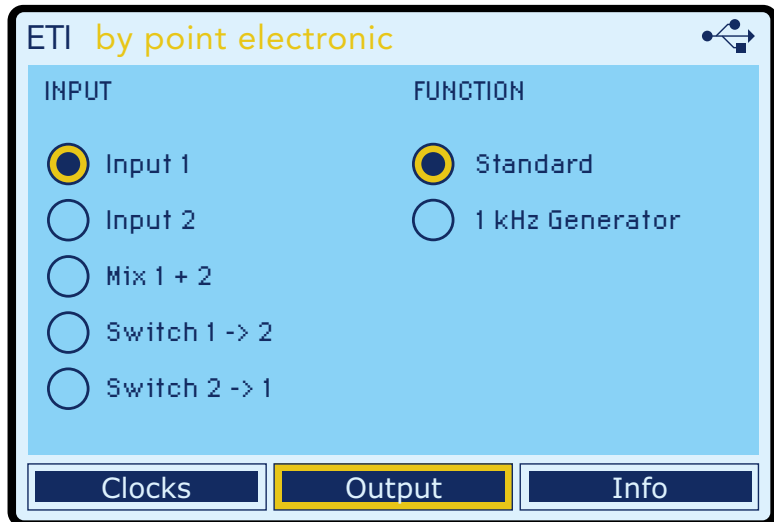

The Output page is divided into the INPUT and FUNCTION columns.



In the INPUT column, the output trigger signals can be configured with the following options:

Option	Description
Input 1	The signals from input channel 1 are used as output trigger signals. 📖 see "Manual switching of trigger signals" on page 26
Input 2	The signals from input channel 2 are used as output trigger signals. 📖 see "Manual switching of trigger signals" on page 26
Mix 1 + 2	The signals from input channels 1 and 2 are mixed and used as the output trigger signal. 📖 Only input trigger signals of the same signal mode are mixed. 📖 see "Mixing trigger signals" on page 28
Switch 1 -> 2	External (automatic) switching is set for input channel 1. 📖 see "Automatic switching of trigger signals" on page 27

Continuation next page ...

Option	Description
Switch 2 -> 1	External (automatic) switching is set for input channel 2.  see "Automatic switching of trigger signals" on page 27

In the FUNCTION column, the following options are available:

Option	Description
Standard	The signals from the input channels are used as configured in the INPUT column.
1 kHz Generator	The ETI is used as a signal generator.  This option is used for testing purposes to check whether the trigger is correctly fed into the corresponding device.  see "Generating trigger signals" on page 29

Info The Info page displays information about the device and the currently set configuration.

The following figure shows the touch display with the Info page:

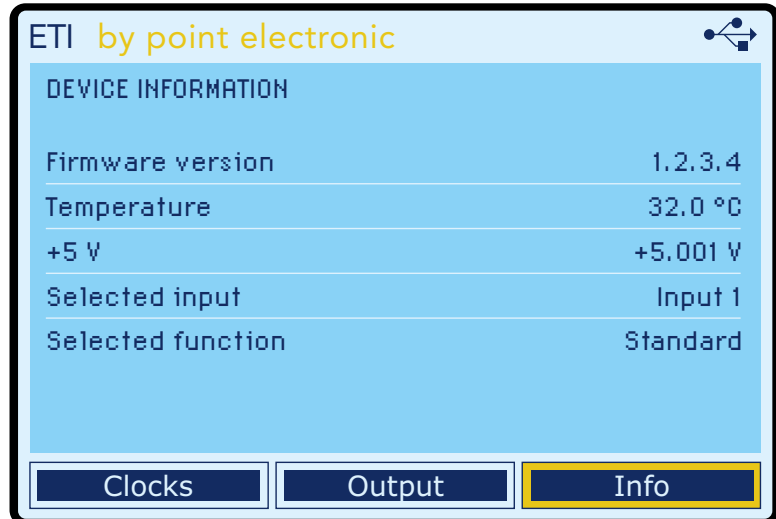

Device labeling

Markings on the device The following figure shows the markings on the back of the device:

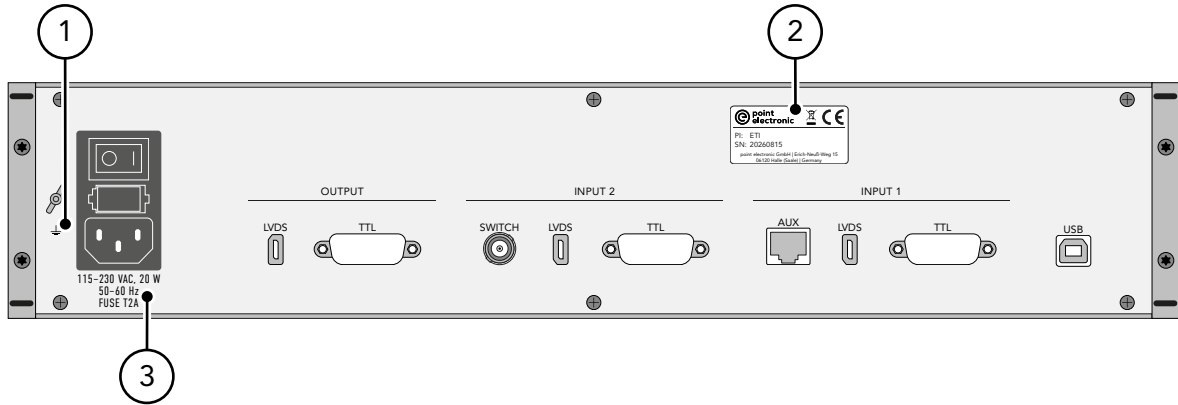

The following table contains information on the markings on the back of the device:

No.	Component
1	Grounding marking
2	Identification plate
3	Information on power supply, power consumption and fuses

Continuation next page ...

Identification plate The following figure shows the identification plate with its components:

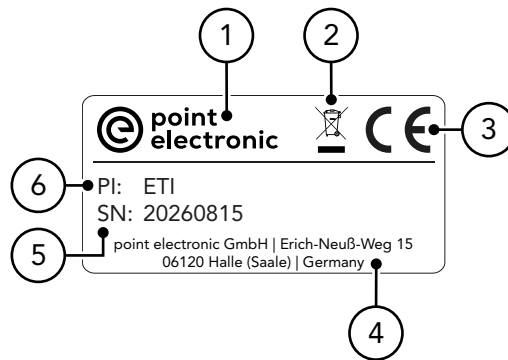

The following table contains information on the components of the identification plate:

No.	Component
1	Manufacturer identification
2	Disposal symbol in accordance with the WEEE directive
3	CE marking
4	Manufacturer address
5	Serial number
6	Device designation

Camera trigger cable

Connection diagram The following figure shows the connection diagram of the cable:

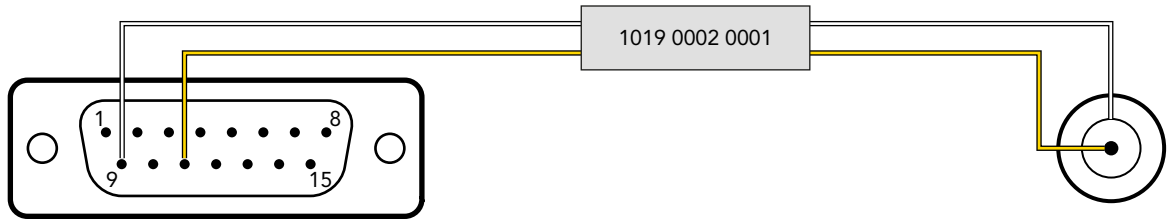

Components and data The following table contains information on the components and data of the cable:

Cable length	3 m
Connectors	15 Pin, D-Sub, plug (male) LEMO FFA.00.250.CTAC15, plug (male)
Cable	Teflon coaxial cable, brown
Item number	1019 0002 0001

Pinout The following table contains information on the pinout of the cable:

Signal	D-Sub	LEMO
PixelClock	Pin 11	Pin
GND	Pin 9	Shield

4 Pinouts of the inputs and outputs

Chapter overview

Purpose This chapter describes the pinouts of the particular inputs and outputs.

Contents This chapter contains the following information:

› LVDS – OUTPUT	42
› TTL – OUTPUT.....	43
› LVDS – INPUT 1/2	44
› TTL – INPUT 1/2	45
› AUX – INPUT 1	46

LVDS – OUTPUT

Type 10 Pin, ix Industrial, perpendicular upright, socket (female), Type B

Numbering The following table contains information on the numbering of the connections for the respective shape:

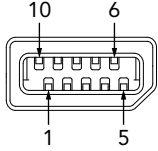
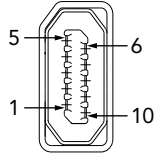
Shape	Numbering (view from outside)
Plug	
Socket	

Assignment The following table contains information on the assignment of the connection numbers:

No.	Assignment
1	LineClock Out +
2	LineClock Out –
3	GND
4	FrameClock Out +
5	FrameClock Out –
6	PixelClock Out +
7	PixelClock Out –
8	GND
9	BeamBlanker Out +
10	BeamBlanker Out –
Housing	Shield

TTL – OUTPUT

Type 15 Pin, D-Sub, socket (female)

Numbering The following table contains information on the numbering of the connections for the respective shape:

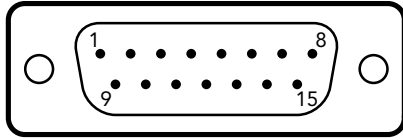
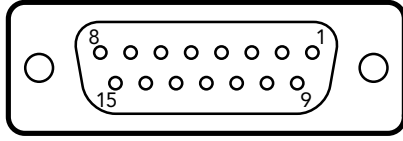
Shape	Numbering (view from outside)
Plug	
Socket	

Assignment The following table contains information on the assignment of the connection numbers:

No.	Assignment	Type
1	–	–
2	–	–
3	–	–
4	–	–
5	–	–
6	–	–
7	–	–
8	–	–
9	GND	–
10	GND	–
11	PixelClock	5 V TTL
12	LineClock	5 V TTL
13	FrameClock	5 V TTL
14	–	–
15	BeamBlanker	5 V TTL
Housing	GND	–

LVDS – INPUT 1/2

Type 10 Pin, ix Industrial, perpendicular upright, socket (female), Type A

Numbering The following table contains information on the numbering of the connections for the respective shape:

Shape	Numbering (view from outside)
Plug	
Socket	

Assignment The following table contains information on the assignment of the connection numbers:

No.	Assignment
1	LineClock In +
2	LineClock In -
3	GND
4	FrameClock In +
5	FrameClock In -
6	PixelClock In +
7	PixelClock In -
8	GND
9	BeamBlanker In +
10	BeamBlanker In -
Housing	Shield

TTL – INPUT 1/2

Type 15 Pin, D-Sub, plug (male)

Numbering The following table contains information on the numbering of the connections for the respective shape:

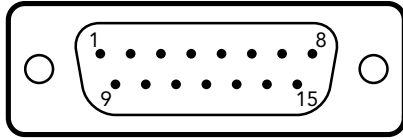
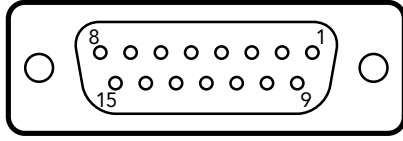
Shape	Numbering (view from outside)
Plug	
Socket	

Assignment The following table contains information on the assignment of the connection numbers:

No.	Assignment	Type
1	PixelClock	5 V TTL
2	LineClock	5 V TTL
3	FrameClock	5 V TTL
4	–	–
5	ExtScan	5 V TTL
6	–	–
7	BeamBlanker	5 V TTL
8	–	–
9	GND	
10	GND	
11	–	–
12	–	–
13	–	–
14	–	–
15	–	–
Housing	GND	

AUX – INPUT 1

Type RJ-45, socket (female)

Numbering The following table contains information on the numbering of the connections for the respective shape:

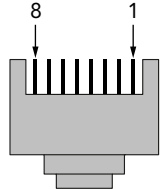
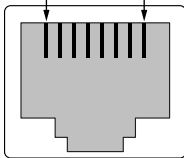
Shape	Numbering (view from outside)
Plug	
Socket	

Assignment The following table contains information on the assignment of the connection numbers:

No.	Assignment
1	
2	
3	ExternalTriggerClock +
4	
5	
6	ExternalTriggerClock –
7	
8	
Housing	GND



5 Installation and configuration

Chapter overview

Purpose This chapter contains descriptions and instructions on installation and configuration of the device.

Contents This chapter contains the following information:

- › Mounting in a 19-inch rack 48
- › Connecting to the power supply 50

Mounting in a 19-inch rack

Installation site Ensure that the installation site adheres to the stipulated operating conditions.

 see "Operating conditions" on page 58

19-inch rack Ensure that the 19-inch rack is equipped with horizontal mounting rails for each built-in device.

Mounting Complete the following steps to mount the device in a 19-inch rack:

WARNING

Risk of injury when lifting, holding and carrying the device!

The weight of the device can lead to injuries and damage to health when lifting, holding and carrying it.

- Always assemble/disassemble the appliance in pairs.
- Wear the prescribed protective work clothing (e.g. safety shoes).

NOTICE

Always ensure accessibility!

When positioning the device, please ensure that on-off switch and all connectors are accessible without obstructions.

Continuation next page ...

1. Place the device in a 19-inch rack.
 - i** Mind the installation height of two rack units (U).
 - ⚠** Ensure that the device rests on the horizontal mounting rails in the rack.
2. Fix the device to the frame with four screws.

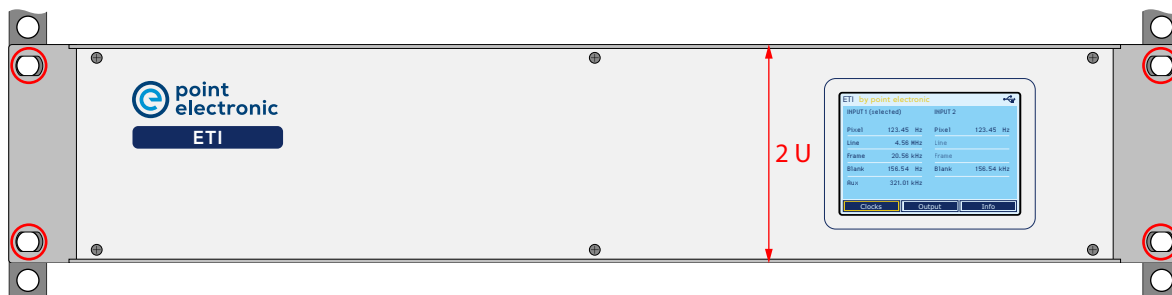

3. Tighten the four screws hand-tight.

Connecting to the power supply

Steps Complete the following steps to connect the device to the power supply:

NOTICE

Mind the device connectors!

When connecting the device, please refer to the description of the unit's backside.

 see "Back panel" on page 33

1. Connect the grounding to the device.

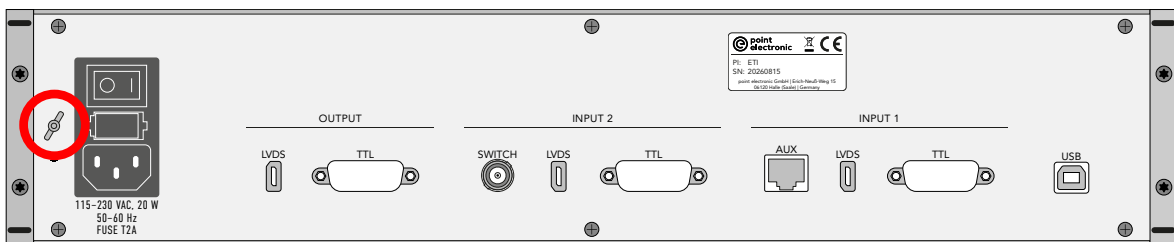

 **The device and the microscope must be connected to the same grounding!**

2. Connect the AC power cable to the device.

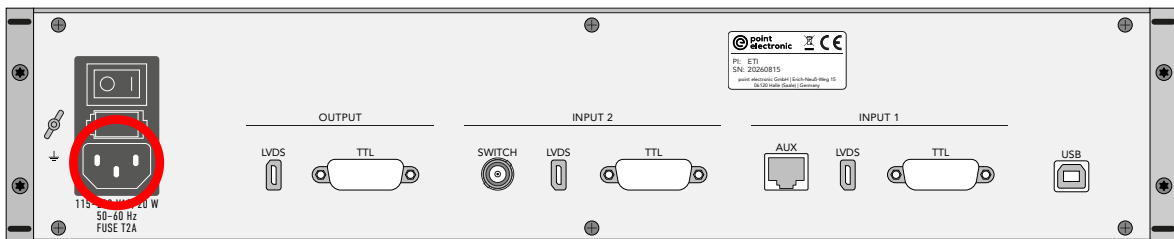

 **Use the AC power cable included in the scope of delivery or an AC power cable that meets the same requirements!**

3. Connect the AC power cable to a power supply.

 **The power supply must comply with the specified requirements!**

 see "Device specifications" on page 59



6 Maintenance

Chapter overview

Purpose This chapter contains instructions on the maintenance of the device.

Contents This chapter contains the following information:

- › Disconnecting from the power supply 52
- › Replacing the fuses 53

Disconnecting from the power supply

Steps Complete the following steps to disconnect the device from the power supply:

NOTICE

The device's on/off switch is not a load-breaking switch!

Before performing any maintenance, disconnect the power cable from the device.

1. Turn off the device using the on/off switch.

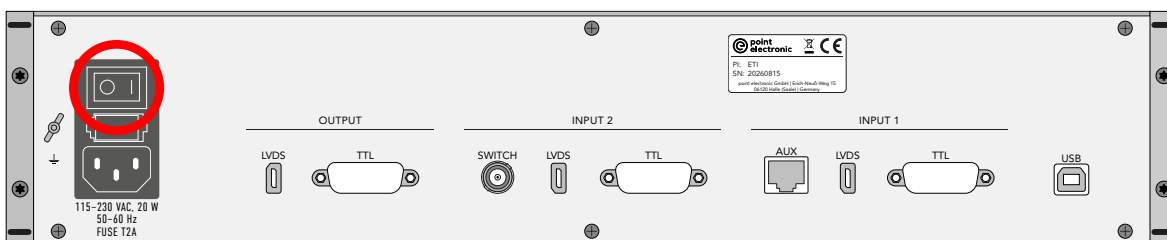

2. Unplug the device's power cable from the power outlet.

3. Unplug the power cable from the device.

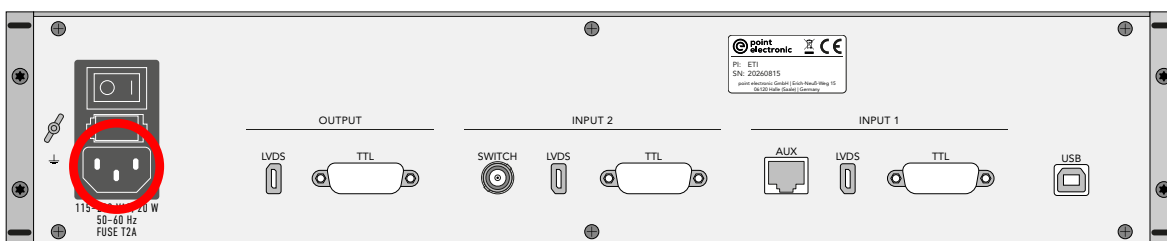

Replacing the fuses

Position of the fuses The fuses are located at the back of the device.

 see "Back panel" on page 33

DANGER

Risk of death by electrocution!

Body contact with live parts may lead to death or serious injuries as well as the destruction or damaging of components.

- Prior to the replacement of the fuses, please make sure that the device is de-energized and secured against unintentional starting (restart).

Before getting started Complete the following steps before replacing the fuses of the device:

1. Disconnect the device from the power supply.

 see "Disconnecting from the power supply" on page 52

2. Remove all connected cables from the device.

Continuation next page ...

Steps Complete the following steps to replace the fuses of the device:

1. Pinch the locking tongues of the fuse holder and pull the fuse holder from the slot.

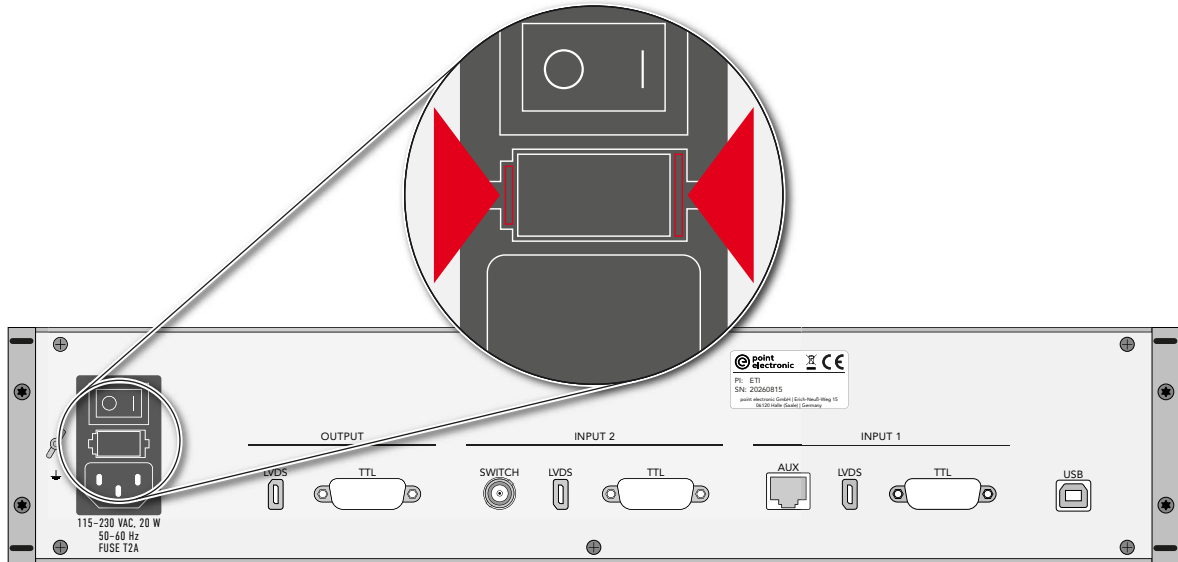

2. Replace the fuse or the fuses.
⚠ Only use type T2A fuses!
3. Push the fuse holder into the slot until the locking tongues snap in.



7 Disposal

Chapter overview

Purpose This chapter contains information on the disposal of the device.

Contents This chapter contains the following information:
› Recycling and taking back of used equipment 56

Recycling and taking back of used equipment

Disposal in accordance with regulations

Electrical and electronic devices may pose a risk to health and the environment if disposed of incorrectly. They cannot therefore be disposed of as domestic waste according to WEEE Directive 2012/19/EU (Waste Electrical and Electronic Equipment Directive). Instead they must be taken to designated collecting points or returned to the manufacturer.

Electrical and electronic devices must undergo specified recycling processes (e.g. with respect to circuit boards) which enable safe, environmentally compatible re-use or separate disposal of different device elements.

The return of used devices is regulated differently in different places. Find out from your local council about the return conditions for commercially used electronic devices.

The device contains no toxic substances requiring separate identification for disposal such as mercury (Hg), cadmium (Cd), lead (Pb) or chrome 6 (e.g. in circuit boards).

Labeling

The following symbol indicates the legal duty to dispose of electronic devices as stipulated:

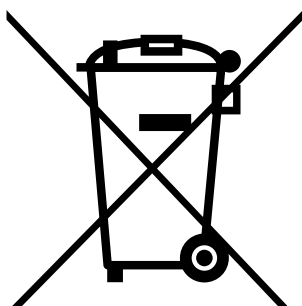



8 Specifications

Chapter overview

Purpose This chapter lists the specifications of the device.

Contents This chapter contains the following information:

- › Operating conditions 58
- › Device specifications 59

Operating conditions

The following table contains information on the operating conditions of the device:

Site of operation	<ul style="list-style-type: none">– indoor– permanently installed device (mounted in a 19-inch rack)– industrial electromagnetic environment
Ambient air	<ul style="list-style-type: none">– average air pressure (approx. 1 bar)– dry– free of dust
Ambient temperature	5 ... 40°C
Humidity	max. 80% (at 31°C, non-condensing)
Altitude	max. 2,000 m

Device specifications

Electrical safety The following table contains information on electrical safety:

Protection class	I
Protection type	IP20
Overvoltage category	II
Contamination level	1

Power supply The following table contains information on the specifications of the power supply:

Supply voltage	115 ... 230 V AC
Frequency	50 ... 60 Hz
Power consumption	max. 20 W
Fluctuation of the supply voltage	max. $\pm 10\%$

Fuses The following table contains information on the fuses:

Number	2 pc. (L and N, replaceable)
Type	T2A
Rating	2 A slow blowing

Dimensions and weight The following table contains information on the dimensions and weights:

Height	88.1 mm (2 U)
Width	482.6 mm (incl. 19-inch mounting brackets)
Depth	290 mm
Weight	approx. 4.2 kg

Continuation next page ...

Dimensional drawing The following figure shows the dimensions of the device:

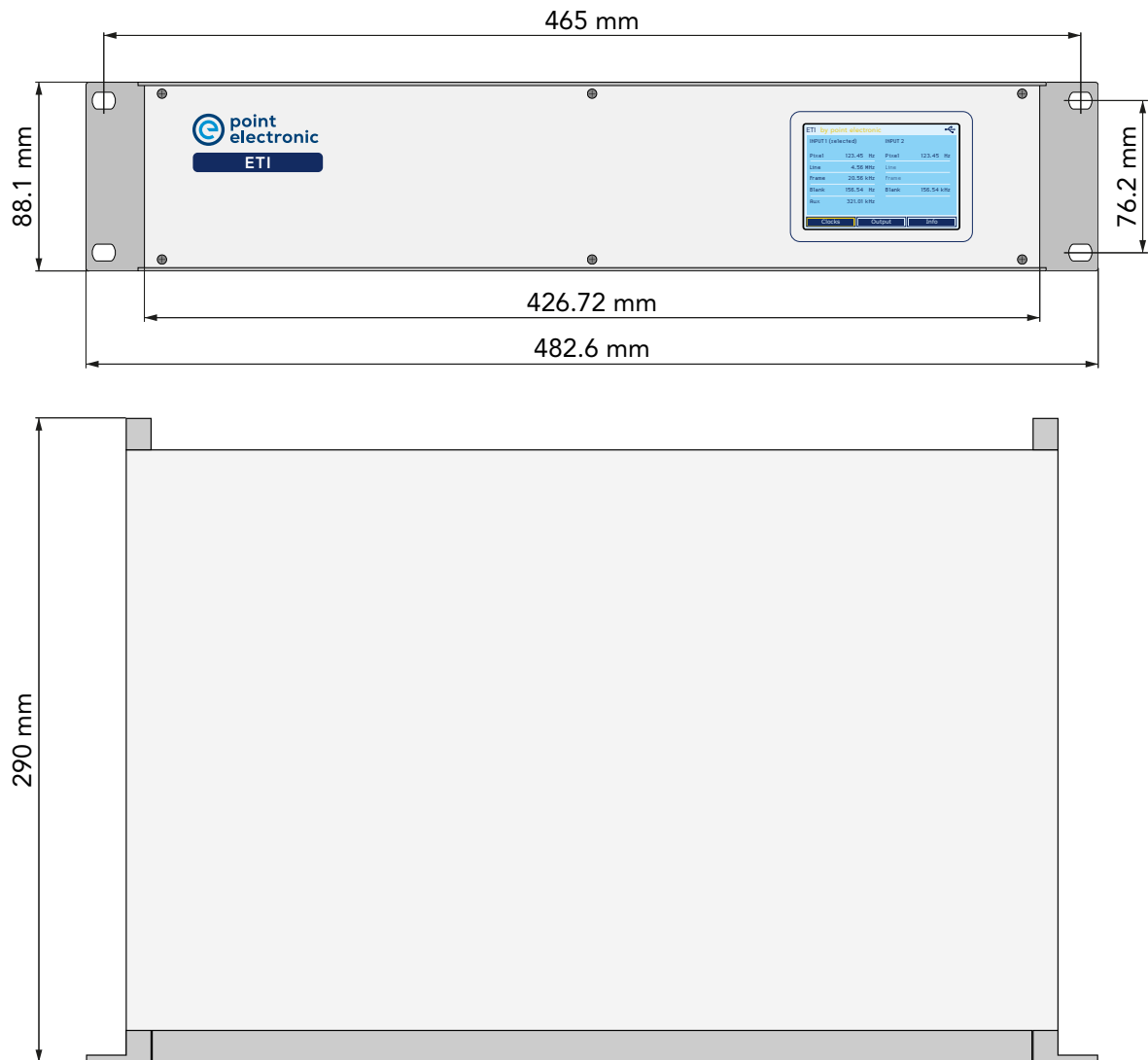

Continuation next page ...

Device housing The following table contains information on the components of the device housing:

Cover plate and base plate	Material: Aluminum Surface: powder-coated RAL 7035 (light gray)
Front panel and rear panel	Material: Aluminum Surface: powder-coated RAL 7035 (light gray)
Frame and profiles	Material: Aluminum Surface: powder-coated RAL 7001 (silver gray)
19-inch mounting brackets	Material: Die-cast aluminum Surface: powder-coated RAL 7001 (silver gray), contact points bare

The manufacturer/distributor

point electronic GmbH
Erich-Neuß-Weg 15
06120 Halle (Saale)
Germany



hereby declares that the following product:

Product/Series	External Trigger Interface
Name(s)	ETI
Description	Hardware controller for switching, mixing, converting, and generating trigger signals
Part number(s)	1019 0001 0001

complies with all relevant provisions of the applicable harmonization legislations and standards.

The manufacturer bears sole responsibility for issuing this Declaration of Conformity. This statement applies to the product in the condition in which it was placed on the market. If the end user subsequently adds parts or makes modifications to the product, this declaration will become completely void.

The following harmonization legislations were applied:

- // EMC Directive (electromagnetic compatibility) 2014/30/EU
- // Low-Voltage Directive 2014/35/EU
- // RoHS Directive 2011/65/EU
- // Ecodesign Directive 2009/125/EG

The following harmonized standards were applied:

- // EN 61010-1:2010 – Safety requirements for electrical equipment for measurement, control and laboratory use - Part 1: General requirements
- // EN IEC 61326-1:2021 – Electrical equipment for measurement, control and laboratory use - EMC requirements - Part 1: General requirements

Place/date of Issue: Halle (Saale), 27.04.2026
Name of the signatory: Christoph Sichtung
Position within the company: CEO point electronic GmbH

Signature:



point electronic GmbH
Erich-Neuß-Weg 15
06120 Halle/Germany
Telefon: +49 (0)345 1201190
Telefax: +49 (0)345 1201223
Info@pointelectronic.de